

## Important Safety Instructions

1. Please read this user manual prior to using the Bread Machine! Please comply with all safety information in order to avoid damages to your unit caused by improper use!
2. If this Bread Machine should be passed on to third parties, please also enclose this user manual.
3. In case of improper use or wrong operation, no liability is accepted for possible damages.
4. Prior to use, please check whether the power supply type and voltage rating correspond to the data listed on the type plate.
5. Use this unit only for its intended use. This bread machine is intended only for private use, not for commercial applications.
6. The Bread Machine is not suitable for outdoor use.
7. Always supervise children when using electronic devices, since they might not be able to recognise the dangers inherent in handling electronic devices.
8. Place the Bread Machine only on a level, sturdy and heat-resistant surface, away from gas flames or stoves and heaters and out of reach of children.
9. Do not use the Bread Machine if the Bread Machine itself or the power cable seems damaged or if the Bread Machine has been dropped.
10. Immediately disconnect the power plug in the event of damages or malfunctions.
11. Do not attempt to repair the Bread Machine yourself. In case of defects, this Bread Machine may only be repaired by qualified professionals. Do not open the unit casing under any circumstances. Danger to life by electric shock!
12. Do not submerge the Bread Machine in water or other liquids. Please be sure that no liquid enters into the Bread Machine.
13. Prevent damage to the power cable from crushing, bending or rubbing on edges, keep the power cable away from hot surfaces.
14. Never touch the power plug with wet or damp hands.
15. When using an extension cable, this must be suitable for the corresponding power rating.
16. Place all power cables neatly out of the way so as to avoid a possible accidental pulling or tripping.
17. When disconnecting the power cable from the power outlet, do not pull on the power cable, do not wrap the power cable around the unit. Regularly inspect power plug and power cable for damages.
18. Do not insert any foreign objects into the Bread Machine's casing.
19. After each use and prior to cleaning the device, please disconnect the power plug from the power outlet.
20. In case the power cable of this Bread Machine is damaged, it must be replaced by the manufacturer, the manufacturer's authorized service centres or similar qualified personnel, to avoid hazards.
21. Only use accessories, which were enclosed with the Bread Machine.
22. The bread machine may be switched on only after the baking pan was filled with ingredients and inserted into the Bread Machine. Operating without ingredients can cause the device to overheat.
23. Disconnect the power plug from the power supply prior to removing the baking pan from the Bread Machine.
24. Danger of Burns! The baking pan will be very hot. Always use oven mitts or potholders when removing the baking pan from the Bread Machine. Please allow all metal parts to cool off before touching them.
25. Do not touch any moving parts.
26. Please be careful when moving the Bread Machine while it is filled with liquid.
27. Once the Bread Machine is switched on and immediately after it is switched off, please maintain a safety distance of 5 cm around the bread machine. Please keep in mind that the exterior of the Bread Machine will become very hot during operation and that the air is superheated if steam is released.
28. The components of the bread machine, excluding the dough hook (3) and baking pan (2) are not dishwasher safe and must only be cleaned by hand.
29. Never leave the unit unsupervised while it is in operation or timer operation.
30. Do not cover the Bread Machine while it is switched on. Heat and steam must be able to be released without obstructions. Never use the bread machine near flammable material. Danger of fire!
31. Never attempt to remove foods from the bread machine while it is switched on or while the power plug is still connected to the power supply.
32. Bulky food items, metal foils, packaging or similar items may not be placed into the Bread Machine.

## Description of Bread Machine

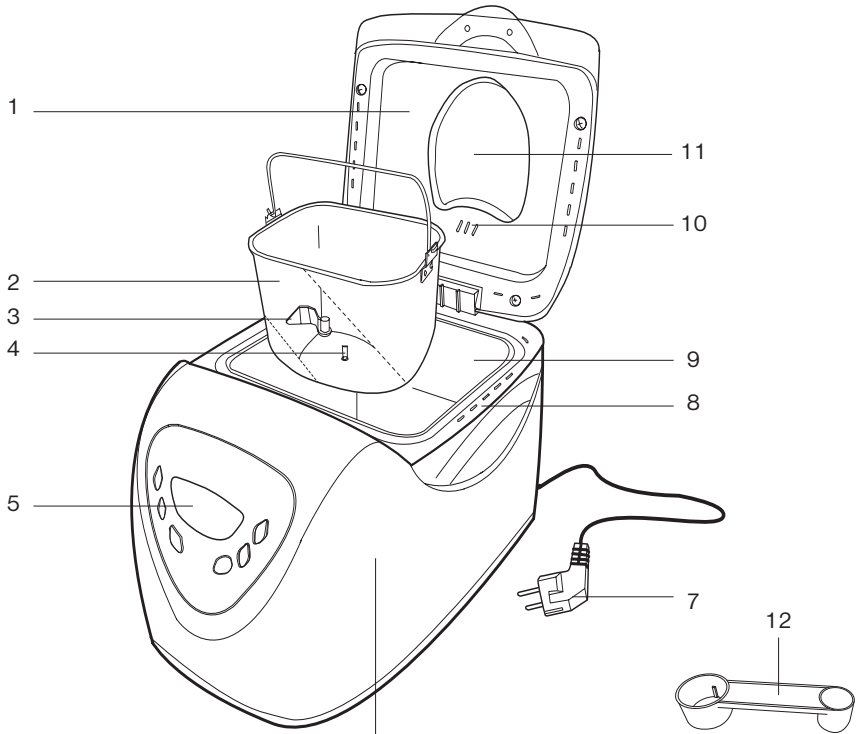

1. Cover
2. Baking pan
3. Dough hook
4. Drive axle
5. Operating panel and control elements with LCD screen
6. Casing
7. Power cable with power plug
8. Ventilation openings
9. Baking compartment
10. Steam release openings
11. Viewing window
12. Measuring spoon
13. Measuring cup

## Description of Bread Machine

With this bread machine, you will be able to

- use store-bought bread mixes. The recipe is usually printed on or enclosed in the packaging.
- bake bread according to the enclosed recipes or commercially available recipe books. This bread machine is equipped with the functions kneading, rising and baking.
- knead dough, e.g. for pasta, baked goods or dinner rolls.
- preserve jam.
  
- This bread machine is suitable for baking bread with a maximum total weight of 1000 g. Never fill the baking pan (2) with ingredients, including liquids, exceeding this amount.
  
- **Loss of electric power:**  
This Bread Machine is equipped with a power loss safety function. Therefore, the Bread Machine will continue the program, which was used last, after a power outage of less than 15 minutes. However, even a short power outage could cause the Bread Machine to restart. In this event, or in the event of longer power outages, it is possible to finish baking the dough by pushing the key **START/STOP**.

## Programs and Operating Panel

- **Key MENU**  
The bread machine is equipped with 12 programs, which can be selected by pushing the key **MENU** in the operating and control panel (5). Push the key **MENU** until the desired program appears on the LCD screen (5).
- **1 - Basic**  
Program for white and mixed breads consisting mainly of white flour (wheat/rye). When adding a small amount (10-20%) of rolled or whole grains, this program can also be used.
- **2 - Baguette**  
Program for bread made of white, finely ground flour, French style bread, and light breads with crunchy crust.
- **3 - Whole grain bread**  
Program for breads with a high content of whole wheat and rye flour. These breads are usually heavy and more compact than breads made from white flour.
- **4 - Quick**  
Use this program to bake bread in approx. half the time. The bread will be of a less fine texture and not quite so flavourful.
- **5 - Sweet bread**  
Program for baked goods, cakes and sweet bread, also for recipes using additional sugar, raisings or chocolate.
- **6 - Ultra fast I**  
Knead, rise and bake a bread weighing 750 g in the shortest possible time. The bread is usually a bit smaller and rougher in comparison to the program Quick.
- **7 - Ultra fast II**  
Same as Ultra Fast I, but for a bread weighing 1000 g.
- **8 - Knead dough**  
Use for, e.g. yeast dough to bake braids or rolls.  
Program without baking phase
- **9 - Jam**  
Use to preserve your own jam.
- **10 - Cakes**  
Knead, rise and bake using baking powder.
- **11 - Sandwich**  
Knead, rise and bake for a sandwich. For baking light bread with a thin crust.

## Programs and Operating Panel

- **12 - Baking**

Use this program exclusively for baking, without kneading the dough or letting it rise. You can also use this program to re-bake bread, which was not completely baked.

- **Key START/STOP**

Use the key **START/STOP** on the operating and control panel (5) to start or pause the program selected by you. After selecting the program using the key **MENU**, simply push the key **START/STOP** to start the program. To momentarily interrupt the program, push and hold the key **START/STOP** until you hear a beep.

- **Note:** Whenever this key is pushed, a short signal will sound.

- **Key COLOR (level of browning)**

The level of browning can be selected for programs 1-7. If the key **COLOR** is pushed, the time displayed in the LCD screen (5) will change and an arrow will indicate whether the level **LIGHT**, **MEDIUM**, or **DARK** has been selected



<b>LIGHT</b>	for a light coloured crust
<b>MEDIUM</b>	for a medium coloured crust
<b>DARK</b>	for a dark coloured crust

- **Key LOAF SIZE**

The weight of the bread can be selected for programs 1-3, 5, 11. The device is preset to **2.0 lb** (approx. 1.000 g). Push the key **LOAF SIZE** until the black mark on the LCD screen (5) highlights the desired size.

<b>1.5lb. approx.</b>	750 g
<b>2.0lb. approx.</b>	1.000 g

- **Timer keys**  

Use the keys  and  to set the total time, after which the bread should be finished. The timer can be pre-programmed to max. 13 hours.



Each time the keys  and  are pushed, the timer will advance or regress by 10 minutes.

- **Note:** The preset program times cannot be changed.

### Timer Operation – example:

(applies only for programs 1, 2, 3, 4, 5, 8, 9, 10, 11, and 12)

Please also observe the information listed under *Start-up Operation*.

- Let's assume that the time is 20:30 (8:30 p.m.) and the bread should be finished at 7:00 (7 a.m.). That is 10 hours and 30 minutes from now.
- Add all selected ingredients into the baking pan (2), as listed in your recipe. Please be sure that the yeast does not come into contact with any liquid or salt.
- insert the baking pan (2) into the bread machine and close the cover (1).
- Use the key **MENU** to select the desired program.
- Use the keys  and  to set the timer to **10:30** (time until bread is finished).
- Push the key **START/STOP**. At "Timer", an arrow will appear in the LCD screen (5). The bread will be done at the desired time.
- To stop timer operation, push and hold the key **START/STOP** until you hear a beep. The last selected baking time will appear on the LCD screen (5).
- **Note:** Use the timer operation only to bake bread using store-bought bread mixes, since fresh ingredients, e.g. eggs and milk, can spoil very quickly.

## Prior to Initial Startup

- Remove all packaging material.
- Remove the dough hook (3) and baking pan (2) and clean them using mild dish liquid and warm water. Clean the measuring cup (13) and measuring spoon (12) the same way. Dry all parts. Wipe the exterior side of the Bread Machine with a slightly damp cloth and dry it using a soft cloth.
- Place the Bread Machine vertically on a sturdy, level and heat-resistant surface.

## Startup Operation

- Remove the baking pan (2) from the device and insert the dough hook (3) onto the drive axle (4) located on the floor of the baking pan (2). Please be sure that the dough hook (3) locks.
- Fill the selected and measured ingredients into the baking pan (2). (Please also see chapter Ingredients). It is very important to add the ingredients to the baking pan (2) prior to inserting the baking pan (2) into the bread machine. Otherwise, the bread machine will be soiled or the heating coils might be damaged. Add the ingredients, in the order listed in the recipe, into the baking pan (2). First, add all liquid ingredients and then the flour. Sugar and salt should be evenly distributed along the side of the flour. Form a small well in the flour, add the yeast into the well. Please be sure that the yeast does not come into contact with salt or liquid.
- Please be sure that the exterior side of the baking pan (2) is clean and then insert the baking pan (2) into the casing (6). Carefully push the baking pan (2) down on both sides, until it locks with a clearly audible sound.
- Connect the power plug (7) to a suitable power supply. You will hear a beep.
- The baking time of program 1 will be displayed on the LCD screen (1), at the setting for **medium browning** and a bread size of **1000 g**.
- Push the key **MENU** until the desired program is displayed on the LCD screen (5).
- Use the keys **COLOR** and **LOAF SIZE** to select the desired settings (please also see Program Selection).
- If the timer is to be used, please set it now (please also see Timer Operation)
- To start the program, push the key **START/STOP**. The time required for the selected program will be displayed on the LCD screen (5) (except for timer operation).
- The program will now start. The time displayed on the LCD screen (5) will count down. The bread machine now completes various baking processes. Kneading, rising of the dough and baking – depending on the selected program.
- During the kneading process, the device will mix the ingredients for several minutes. It is normal for the Bread Machine to audibly vibrate during the kneading process.
- The Bread Machine will then allow the dough to rise. During this time, the yeast will become active. It is possible for the viewing window (11) to fog up during this time. After some time, the condensation will escape through the steam release openings (10).
- When using the programs 1, 2, 3, 5 and 11, the device will sound a signal to remind you to add further ingredients, e.g. raisins or nuts, if required. Open the cover (1) for only a short moment to prevent the dough from collapsing.
- To momentarily interrupt the baking process, push and hold the key **START/STOP** for approx. 2 seconds. Once the baking process has been interrupted, it cannot continue. In this case, please start program 12 = **baking**.
- **Attention!** During operation, the ventilation openings (8) and steam release openings (10) must remain uncovered.
- If smoke escapes from the cover, please keep the cover closed. In this event, please stop the program by pushing and holding the key **START/STOP** for approx. 2 seconds, and then disconnect the power plug (7) from the power outlet. Never extinguish possibly smoking dough with water! Smoke can be created if the dough rises above the rim of the baking pan (2) and comes into contact with the heat coil. Therefore, it is important to adhere to the measurements listed in the recipes!

## Startup Operation

- Avoid opening the bread machine during operation in order to achieve optimum baking results. You can watch the baking process through the viewing window (11).
- **After baking:** Once the program is finished, 10 signals will sound and the bread machine will automatically switch to **warming**. The bread can remain in the unit for another 60 minutes without moisture soaking the bread. However, the bread should be removed from the baking pan (2) as soon as possible.
- Stop the warming process by pushing and holding the key **START/STOP** for approx. 2 seconds.
- Please disconnect the power plug (7) from the power outlet to be sure that the device is completely shut down.
- Open the cover (1). The baking pan (2) and the bread will be very hot! Use pot holders and oven mitts to remove the baking pan (2) from the device. Place the baking pan (2) on a heat resistant surface, never on a tablecloth or plastic surface.
- Allow the baking pan (2) to cool down for approx. 5 minutes before removing the bread from the pan. Hold the baking pan (2) diagonally above a baking rack and slightly shake it until the bread comes loose.
- If the dough hook (3) is still inserted into the bread, remove it using a blunt object. Please do not use any metal objects to remove the dough hook (3) as this could damage the surface coating of the dough hook (3).
- The bread should cool off for another 15-30 minutes before eating it.
- If a second bread is to be baked and if **H:HH** flashes on the LCD screen (5) and a signal sounds, the bread machine is not yet sufficiently cooled off. Wait another 10 – 20 minutes before using the device again.
- Always allow unit to cool off before cleaning it.

## Cleaning and Care

- Prior to cleaning the Bread Machine, please be sure that the power plug (7) is disconnected from the power supply and that the Bread Machine is completely cooled off.
- Remove the baking pan (2) from the device and remove the dough hook (3) from the drive axle (4) inside the baking pan (2). The baking pan (2) and dough hook (3) are non-stick coated. This facilitates cleaning. Clean the dough hook (3) and baking pan (2) using a mild dish liquid and warm water. Never use acidic or abrasive cleaning agents or abrasive sponges! If the dough hook (3) is encrusted or hard to remove from the drive axle (4), fill the baking pan (2) with hot water. After approx. 30 minutes, clean and remove the dough hook (3). Carefully dry these parts before replacing them into the Bread Machine.
- The baking pan (2) and dough hook (3) are **dishwasher save**.
- Wipe the baking chamber and exterior side of the Bread Machine with a slightly damp cloth and dry it using a soft cloth.
- Never hold the unit under running water and never submerge the unit in water or other fluids. Never pour water or other liquids into the baking chamber of the Bread Machine.

## Technical specifications

Operational voltage	:	230V~ 50Hz
Power Consumption	:	600 Watt
Timer	:	max. 13 hours

### Environmental Protection

Discarded electric appliances are recyclable and should not be discarded in the domestic waste! Please actively support us in conserving resources and protecting the environment by returning this appliance to the collection centres (if available).

## Ingredients

It is often said that cooking is an art, which depends on the cook's creativity, while baking is a science. This means that the process during which flour, water and yeast are mixed, starts a chemical reaction enabling the creation of bread dough. Please remember that the mix of ingredients produces specific results. Please read the following instructions to understand the role of various ingredients in the bread baking process.

### Ingredients - Temperatures

All ingredients, particularly liquids (water or milk) should be at room temperature, meaning 21 °C. If the ingredients are too cold, e.g. under 10 °C, the yeast will not be activated. Very hot liquids, hotter than 40 °C, can kill the yeast organisms.

#### 1. All-Purpose Flour

All-purpose flour is a mixture of refined hard and soft wheat flour types suitable for baking bread and cakes.

#### 2. Bread Flour

Use bread flour to achieve better results. This flour is ground in order to be particularly suitable for baking breads using yeast. It has a higher content of egg white than all-purpose flour. The protein contained in the flour transforms into gluten as soon as it is mixed with a liquid. Gluten becomes elastic during kneading and forms the texture of the dough. All-purpose flour forms a weak texture and small loaves of bread.

#### 3. Whole Wheat Flour

For whole-wheat flour, the complete grain of wheat is ground. It contains the germ and the bran, which causes the whole-wheat flour to be heavier and also more nutritious than all-purpose flour. Bread loaves baked with whole-wheat flour are usually smaller and heavier than bread loaves made with white flour. To avoid this, whole-wheat flour is often mixed with all purpose, bread or bran flour to achieve taller loaves of bread with a light texture.

#### 4. Rye Flour, Whole Grain Flour

Rye flour is similar to whole-wheat flour. It is also called Graham Flour and has a high fibre content. Rye flour must always be mixed with a large quantity of all-purpose flour, bread or gluten flour, because the gluten content of rye flour is insufficient to form the structure for an evenly risen, grainy loaf of bread.

#### 5. Gluten Flour

Gluten flour is wheat flour, which was treated to remove most of the starch content. What remains is a very high gluten content (gluten is wheat protein, which gives elasticity to bread dough). This flour is usually available at most health food stores. Occasionally, small portions of it are used in combination with flour types with a low gluten content – e.g. wheat flour – to increase volume and achieve a light structure.

#### 6. Cake Flour

Cake flour consists of soft or low-protein types of wheat. It is used for cake recipes.

#### 7. Self-Rising Flour

Self-rising flour contains unnecessary leavening ingredients, which influence the baking of breads and cakes. The use of self rising flour is not recommended.

## Ingredients

### Important note regarding flour types

Even though they look similar, various flour types can vary significantly depending on origin, the process used to grind or store them, etc. You will notice that you must gain experience with several types of flour until you are able to bake perfect loaves of bread. The brochure at hand contains a collection of recommendations for baking, which will be useful to you.

It is also important to store flour correctly. It should be stored in secure, airtight containers. Rye and whole-wheat flour should be stored in the refrigerator or a cool location to prevent these types of flour from becoming rancid.

### 8. Bran

Unprocessed bran and wheat germs are the coarse external parts of wheat or rye grains. It can be separated from the flour by sieving it. Small quantities of bran and germ are often added to bread to increase its nutritional value, to make it heavier and give it flavour. It is also used to increase bread texture.

### 9. Corn and Oat flour

Corn and oat flour is made by grinding coarse kernels of yellow or white corn or pre-treated oat grains. They are often used to improve flavour and lighten the texture.

### 10. Split Wheat

Split wheat is very coarse. This type of wheat consists of wheat grains cut into fragments. It gives a nutty flavour and crunchy texture to whole grain breads.

### 11. Seven-Grain Mix

Seven-grain mixes are a mix of split wheat, bran, rye, corn kernels, flax seeds and hulled millet.

### 12. Sugar

Sugar is important for the colour and flavour of bread. Sugar is food for yeast and supports the fermenting process. The recipes listed in the above manual are based on the use of crystallized sugar. Do not use powdered sugar or brown sugar unless this is specifically recommended. Artificial sweeteners cannot be used as a sugar substitute as the yeast will not be properly activated.

### 13. Salt

Salt is a balancing element for the flavour of breads and cakes as well as the colour of the crust, which is formed during baking. Salt also limits the rising ability of yeast. The quantity of salt listed in recipes should therefore not be increased. For diet reasons, salt can even be omitted. However, it is possible for the bread to rise higher than normal if salt is omitted.

### 14. Yeast – Active Dry Yeast

Yeast produces gas (carbon dioxide) during the fermenting process, which lightens the bread dough. Yeast must be able to feed itself with sugar and carbohydrates of the flour in order to produce this gas. All recipes calling for the use of yeast require active, grainy yeast. Basically, there are three different types of yeast: fresh yeast, dry yeast and instant yeast. We recommend using traditional dry yeast. Instant yeast may be used in small amounts (note: all recipes listed in the above manual are based on the use of dry yeast. The use of fresh or pressed baking yeast is not recommended, since it achieves weaker results). Yeast must always be stored in the refrigerator so that it remains fresh. High temperatures kill yeast organisms. Please be sure to use only fresh yeast. Check the expiration date. Opened yeast packages or cans containing leftover yeast to be used at a later time should be closed immediately after opening, kept air tight and placed in the refrigerator.

## Ingredients

If the bread or dough does not rise, it is usually caused by the use of old yeast. Please perform the following test to determine whether the yeast is old and inactive:

- A) Fill a small bowl or cup half full with lukewarm water.
- B) Mix in one teaspoon of sugar, then sprinkle two teaspoons yeast on the water surface.
- C) Place the bowl or cup in a warm environment and wait 10 minutes.
- D) The mixture should foam and smell like yeast. If this is not the case, please purchase fresh yeast.

### 15. Liquids

Liquids, e.g. milk (1%, 2%, whole milk or fat-free milk) or a combination of milk powder and water can be used to bake bread. Milk improves flavour, gives bread a smooth structure and causes the crust to be softer, while using only water results in a crunchy crust. Juices are sometimes listed as the liquid ingredient (apple juice, orange juice, etc.) to improve the flavour of the bread.

### 16. Eggs

Eggs give bread and cake dough a rich and smooth structure. The recipes listed in this manual are based on the use of large eggs.

### 17. Fat

Oil, baking fat, butter and margarine <<shorten>> or soften the structure of yeast breads. The unique crust and structure of French bread (baguette) is caused by omitting butter. Breads using butter will remain "fresh" longer. Please keep in mind that butter or margarine should always be soft or in liquid form when it is added to the ingredients. Avoid using soft or diet margarine, which does not have the required fat content.

### 18. Baking Powder

Baking powder is used as a leavening agent for fast-baking breads and cakes. This leavening agent does not require time to rise prior to baking, since the chemical reaction will occur only after liquid ingredients are added.

### 19. Baking Soda

Baking soda is another leavening agent, which should not be confused or replaced with baking powder. Baking soda also does not require time to rise prior to baking, since the chemical reaction will occur only during the baking process.

## Measuring ingredients

The key – and the most important step when using bread machines – is the exact and careful measurement of ingredients. It is extraordinarily important to precisely measure liquid and solid ingredients. Otherwise, the result might be unsatisfactory. The ingredients must also be added to the baking pan in the order listed in the recipe. Liquid and solid ingredients require the following methods for measuring, which vary somewhat:

### Measuring liquids

To measure liquids like water or milk, we recommend using transparent containers made of plastic or glass or the enclosed measuring cup (10). To read the value of the respective quantity, first place the container on a horizontal, level surface at eye level (do not read values at an angle). The level of the liquid must correspond to the respective mark on the container. An <<estimated>> quantity is not recommended; it could influence the balance of the recipe.

### Measuring solid ingredients

Use the enclosed measuring spoon (9):

- the small spoon corresponds to a teaspoon
- the large spoon corresponds to a tablespoon

## Ingredients

Measuring solid ingredients (different types of flour, in particular) should be performed using standardized measuring cups. Such measuring cups are available in different sizes. Add the ingredients into the measuring cups, one spoon at a time, and "cut" across the rim of the measuring cup using a knife. Tapping the measuring cup or using it like a scoop can cause the ingredients to be compacted, therefore resulting in larger quantities. This additional quantity can influence the balance of the recipe. Do not sift flour.

Small quantities of solid or liquid ingredients (e.g. yeast, sugar, salt, milk powder, honey, molasses) should be measured using the enclosed measuring spoon **(9)**. Decisive is the "cut", not the heaped quantity. This minor difference can influence the balance of the recipe.

### Miscellaneous tips

- Always add all ingredients to the baking pan **(2)**, so that the yeast does not come into contact with any liquids.
- At higher elevations (more than 900 m above sea level) or when using very soft water, the yeast's fermenting process will be increased, the dough will rise faster. To avoid excessive rising of the dough, reduce the quantity of yeast by approx. 1/4 of the amount listed in recipes.
- To achieve a satisfactory result, we recommend carefully maintaining a log of all ingredients and recipes used. In the event that a recipe does not achieve satisfactory results, you can then adjust the amount of the respective ingredient accordingly. Please keep in mind that using flour types from various manufacturers can also influence the result. This also applies to other ingredients. For example, never use two different types of yeast for the same bread.

### Special Glazing for Yeast Bread

Give a "professional touch" to your freshly baked bread. Select one of the following glazes for your bread.

#### Egg Glaze

Mix 1 large egg and 1 teaspoon water, apply liberally (note: baste on the dough only prior to baking).

#### Melted Butter Crust

To achieve a soft, tender crust, baste melted butter on top of the freshly baked bread.

#### Milk Glaze

To achieve a softer, shiny crust, baste the freshly baked bread with butter or heavy cream.

#### Sweet Glaze

Mix one cup of sifted, powdered sugar with 1 to 2 tablespoons milk. Drip over raising bread or sweet bread.

Poppy, sesame, caraway, corn meal/dates: Liberally sprinkle select ingredients over the glazed bread.

## Troubleshooting

### **The dough hook is stuck in the bread loaf**

Remove the dough hook (1) from the bread using a blunt object, e.g. a piece of wood. Please avoid damaging the non-stick surface of the dough hook (1).

### **The bread did not rise**

You might have used too little or too much yeast or the yeast was past its expiration date. The yeast might have come into contact with salt – this also influences the rising process of the dough. The cover (5) of the bread maker must remain closed during the baking process. A high content of whole grain flour and grains will limit the rising of the dough, which is completely normal.

### **The bread rose too much**

You might have used too much yeast, flour or water. Use only dry yeast, since fresh yeast can influence the result negatively.

### **The dough is not kneaded, even though the motor runs.**

The kneading dough (1) might not be correctly inserted onto the drive axle (3) or the baking pan (2) was not correctly attached to the drive shaft (6).

### **The bread is soggy**

If, after baking, the bread was left in the baking pan (2) for too long, the moisture contained in the warm bread cannot evaporate. After some time, this will soak the bread.

### **The dough was not kneaded completely**

The ingredients might not have been added to the baking pan (2) in the correct order or the total weight of the ingredients was too high. The butter used might have been too hard or the liquid was too cold.

### **The finished bread is too moist inside**

When using the same recipe next time, add an additional tablespoon of flour or use correspondingly less water or milk. You can also try to reduce the quantity of yeast by max. 1/4.

### **The bread is not baked completely**

You might have selected the wrong program. Replace the bread into the baking pan (2) and finish baking it using program 10.

## Guarantee

Statutory guarantee legislation applies for this equipment.  
Claims are to be reported immediately after their determination.

The right to claim under guarantee expires upon any intervention of the purchaser or third parties. Damages caused by wrong treatment or operation, by false installation or storage, improper connection or installation, as well as other external influences are not covered under the terms of guarantee. We recommend careful reading of the operating instructions.

The right to claim under guarantee must be proven by the purchaser by presentation of the purchase invoice.

**Note:**

1. Should your equipment not function correctly, please firstly check, whether other reasons, e.g. interruption of the power supply, or incorrect handling are the cause.
2. Please note that it is imperative that the following documents and details are produced together with your faulty equipment:
  - Purchase receipt
  - Model description/Type/Brand
  - Description of the experienced defect stating the fault as accurately as possible.

In the case of a claim for guarantee or defects, please contact the place of purchase personally.

GWL 7/02 OS/GB